

		REVISIONS			
ZONE	REV.	DESCRIPTION	DATE	APPROVED	

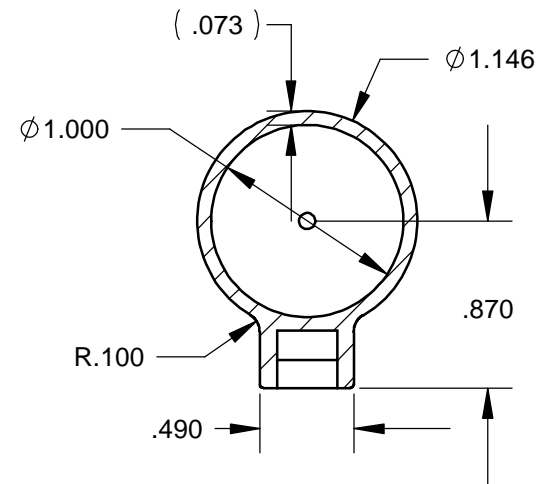
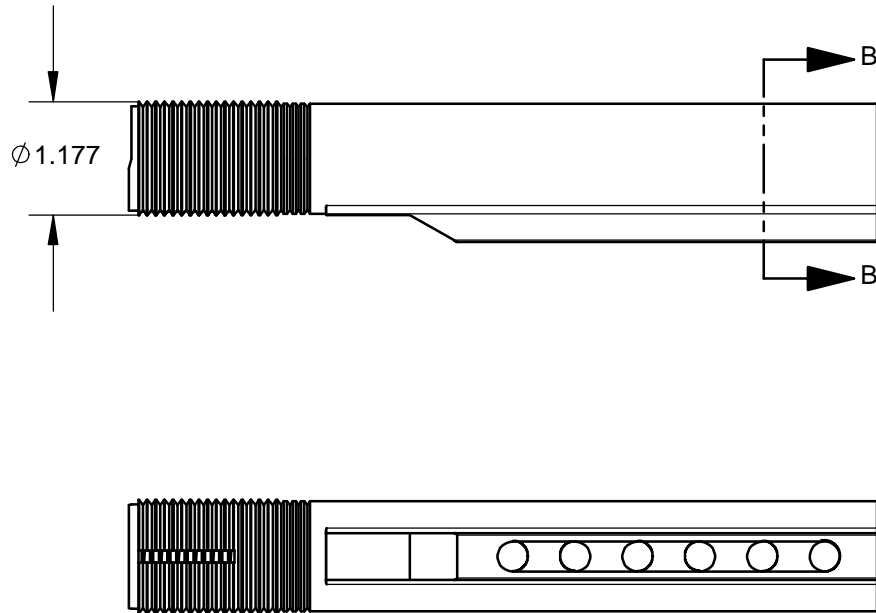

SECTION B-B  
SCALE 1 : 1

**NOTES**

1. Matl. is 7075-T6 machined from forging
2. Hard coat anno per Mil

PARTIAL DRAWING - only critical dimensions and fits are noted. All other dimensions per Solidworks file:

DIMENSIONS ARE IN INCHES

TOLERANCES:  
 FRACTIONAL  $\pm 1/16$   
 ANGULAR: MACH  $\pm 2$  BEND  $\pm 4$   
 TWO PLACE DECIMAL  $\pm .020$   
 THREE PLACE DECIMAL  $\pm .008$   
 FOUR PLACE DECIMAL  $\pm .0005$

MATERIAL

FINISH

DO NOT SCALE DRAWING

	NAME	DATE
DRAWN	BN	DEC 19 05
CHECKED		
ENG APPR.	MM	
MFG APPR.		
Q.A.		

PROPRIETARY AND CONFIDENTIAL

THE INFORMATION CONTAINED IN THIS DRAWING IS THE SOLE PROPERTY OF BOA TECHNOLOGY. ANY REPRODUCTION IN PART OR AS A WHOLE WITHOUT THE WRITTEN PERMISSION OF BOA IS PROHIBITED.

buffer tube - Mil spec M4



**MAGPUL INDUSTRIES**

SIZE	DWG. NO.	REV.
A		

SCALE:1:2    WEIGHT:    SHEET 1 OF 1