



<b>PRODUCT</b>	<b>Folding Trigger Guard</b>	<b>FOLDING TRIGGER GUARD</b>
<b>WEAPON</b>	<b>AR15/M16</b>	
<b>CATEGORY</b>	<b>Installation</b>	
<b>DIFFICULTY LEVEL</b>	<b>Medium/High</b>	
<b>PUBLISHED</b>	<b>03.14.07</b>	
<b>TOOLS REQUIRED</b>	<b>Hammer, 1/16" &amp; 1/8" Roll Pin Punches, 1/16" Hex Key, Small Flat-Head Screwdriver</b>	
<b>PARTS INCLUDED</b>	<b>1/8" Roll Pin</b>	

## Installation of the Folding Enhanced Trigger Guard for the AR15/M16

There are two versions of the Enhanced Trigger Guard: a solid and a folding model. These instructions are for the folding model, and the require parts from the OEM trigger guard assembly. Only a qualified armorer or gunsmith should perform installation of this equipment. If you do not meet these requirements, have a qualified professional perform this installation. *NOTICE: Magpul Industries shall not be responsible for injury, death or damage to property resulting from improper installation, misuse or illegal use of this product.*



**WARNING: Observe safe firearm handling practices at all times. Failure to do so may result in grievous bodily injury or death.**

### PARTS INCLUDED (NOT TO SCALE):

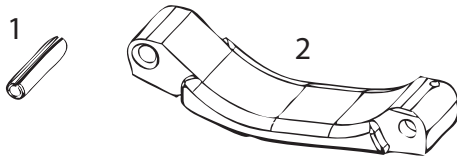

1. 1/8" Roll Pin
2. Folding Enhanced Aluminum Trigger Guard

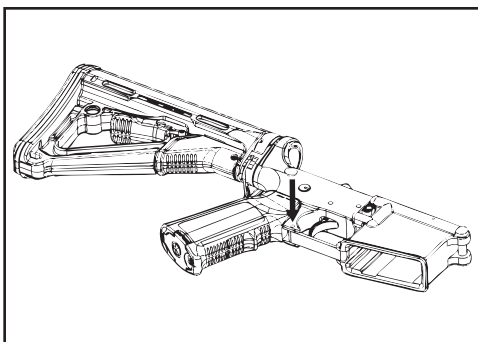

### STEP 1 - Remove Original Trigger Guard

*WARNING: Before beginning installation, make sure the weapon is unloaded and the safety engaged. Lower receiver damage may occur if care is not taken in the removal and installation of the trigger guard. Support the rear area holding the trigger guard pivot roll pin, as the walls may bend when the pin is removed. Remove the upper receiver from the weapon. Using a 1/8" Pin Punch, remove the OEM trigger guard per armorer guidelines.*

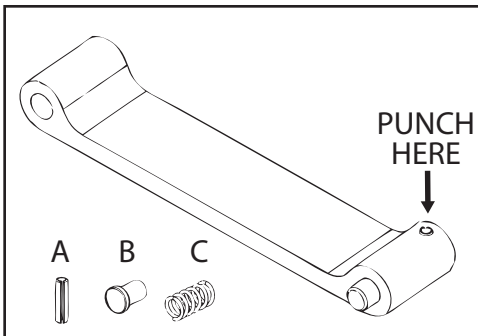

### STEP 2 - Remove Detent and Spring

*Advisory: Before proceeding make sure to use care to avoid losing the small Trigger Guard Assembly parts. These parts are under pressure and are easily lost during removal. Using a 1/16" Roll Pin Punch, carefully remove the Trigger Guard Detent Roll Pin (A). Remove Trigger Guard Detent (B) and Spring (C).*

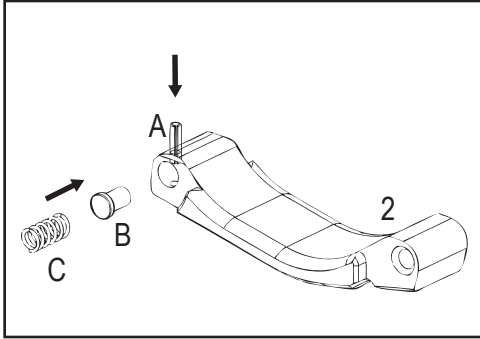

### STEP 3 - Install Detent and Spring

Using a Hammer and 1/16" Roll Pin Punch, install *Trigger Guard Detent Roll Pin (A)* part-way into the *Folding Enhanced Trigger Guard (2)*. Place *Trigger Guard Detent (B)* and *Trigger Guard Detent Spring (C)* in hole. Using a Small Flat-Head Screwdriver, fully compress *detent spring*. Continue installation of *roll pin* until it is flush with the surface.

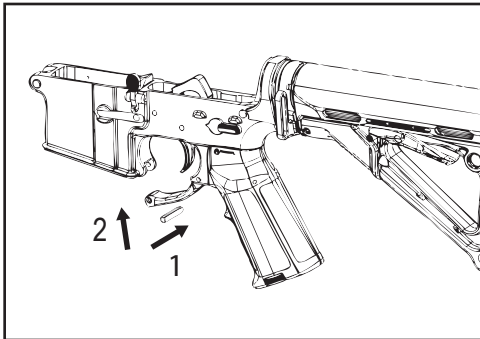

### STEP 4 - Install Folding Enhanced Trigger Guard

Position *Folding Enhanced Trigger Guard (2)* into *Lower Receiver*. Install provided *1/8" Roll Pin (1)* in rear of trigger guard using care not to damage *Lower Receiver*. Do not re-use factory roll pin!

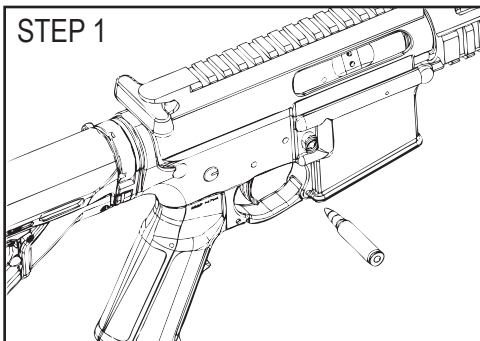

STEP 1

### Folding Instructions

To fold down trigger guard, push in front Trigger Guard Plunger with bullet tip (STEP 1) and rotate downward as shown (STEP 2). This opens up the trigger guard for use with mittens.

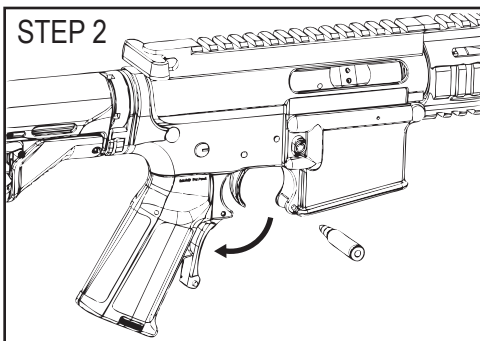

STEP 2

THIS SPACE INTENTIONALLY LEFT BLANK